

# 12V ANGLE LITE

11017

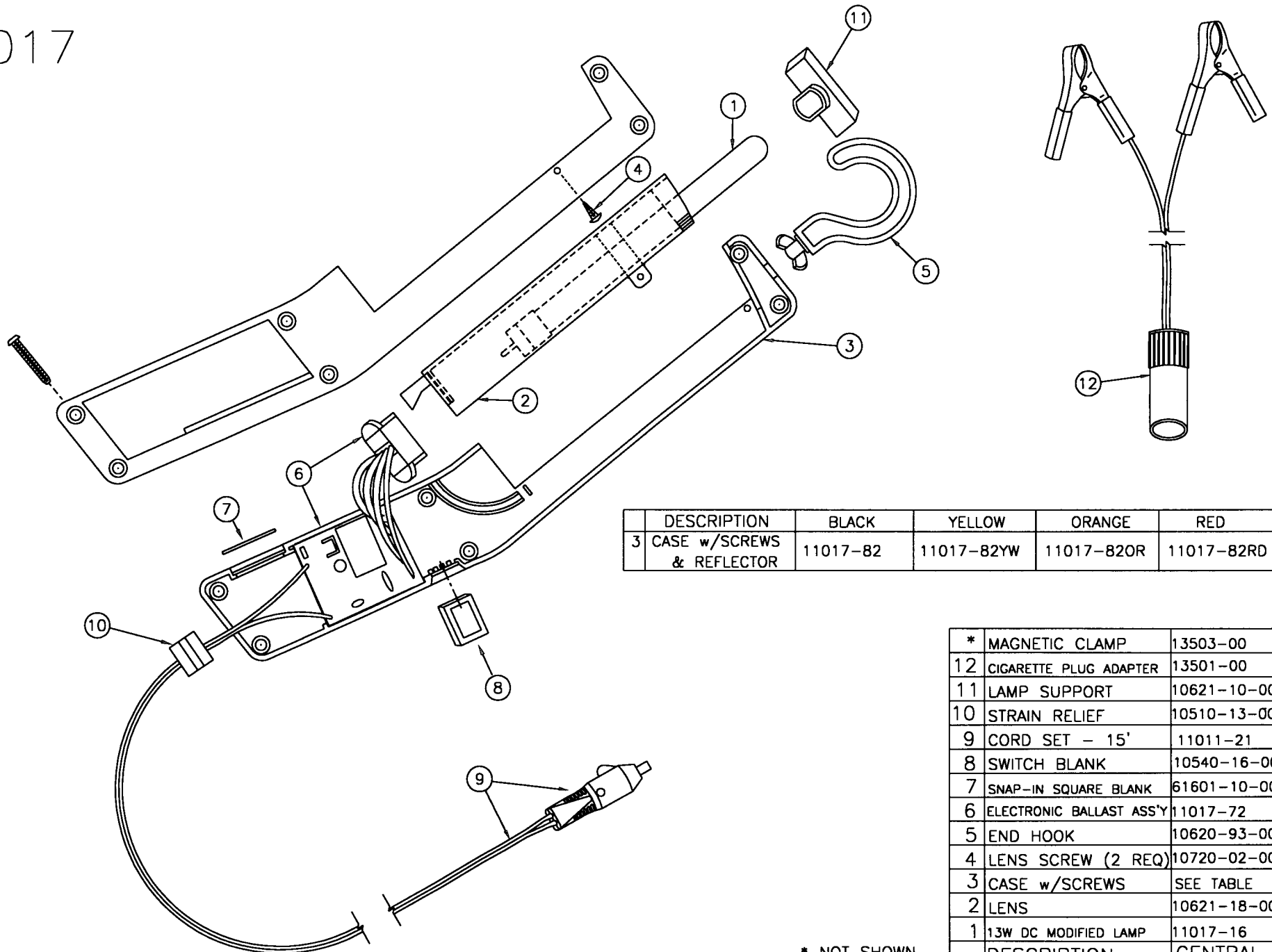

DESCRIPTION	BLACK	YELLOW	ORANGE	RED
3 CASE w/SCREWS & REFLECTOR	11017-82	11017-82YW	11017-82OR	11017-82RD

* MAGNETIC CLAMP	13503-00
12 CIGARETTE PLUG ADAPTER	13501-00
11 LAMP SUPPORT	10621-10-000
10 STRAIN RELIEF	10510-13-000
9 CORD SET - 15'	11011-21
8 SWITCH BLANK	10540-16-000
7 SNAP-IN SQUARE BLANK	61601-10-000
6 ELECTRONIC BALLAST ASS'Y	11017-72
5 END HOOK	10620-93-000
4 LENS SCREW (2 REQ)	10720-02-000
3 CASE w/SCREWS	SEE TABLE
2 LENS	10621-18-000
1 13W DC MODIFIED LAMP	11017-16
DESCRIPTION	CENTRAL #

\* NOT SHOWN