

Injector Timing Gage

For Cummins Engines (NH, NT, L10 & V Models)

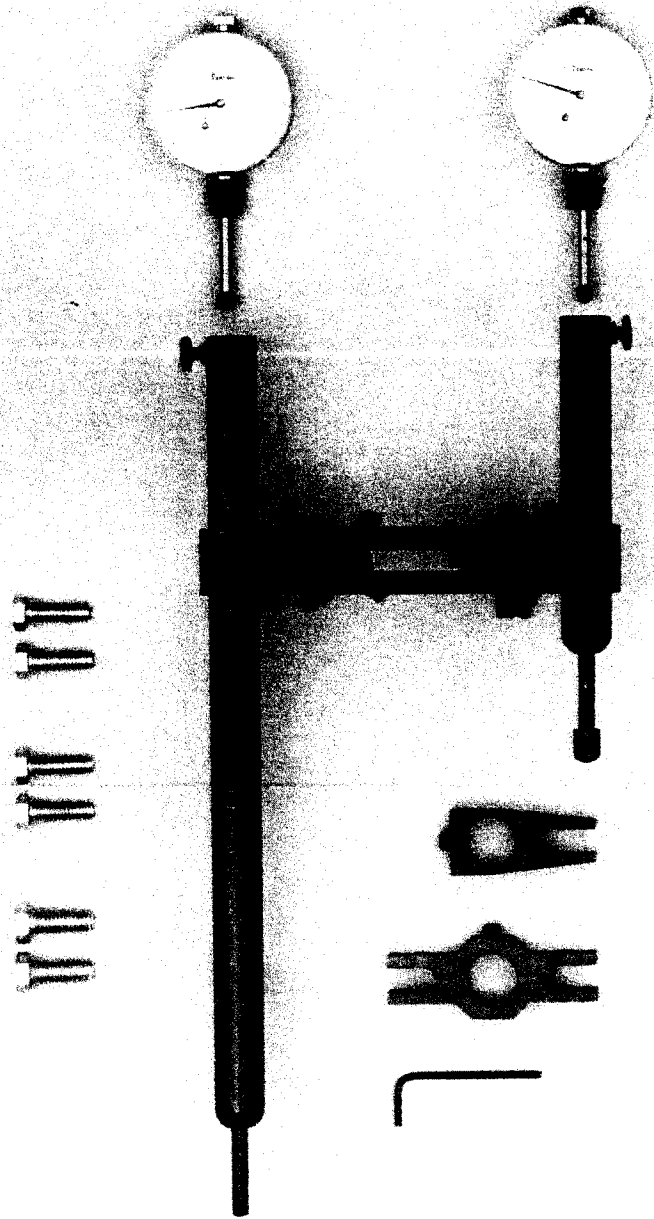

 **Central[®] Tools, Inc.**
"Your Automotive Measuring People"

Timing Gage Set-up

The Injector Timing Gage, 6433, from Central Tool, Inc. is a versatile tool designed to precisely measure injector timing relative to position. Before proceeding, read the chapter on timing in your Cummins Service Manual and consult the manual for specifications and the procedure to alter timing for correct setting.

These instructions are suggested method of using the Central Injector Timing Gage. However, for any particular application your Cummins Service Manual is the final authority.

Turn engine to where the injector push rod is at the low point of its travel. Slide gage hold-down base onto the long indicator support body. With base set-screw finger tight, lower support into injector sleeve so that lower end of the support is bottomed in the injector seat. Slide base to correct position on support and securely tighten base set-screw.

Securely tighten base to head with correct screws. Adjust slide clamps so that the short support body lines up with the push tube. Tighten both clamp knobs and check that the push tube is free to move without binding.

Place indicators in support bodies and tighten thumb screws very lightly, allowing indicators to slide up if either should bottom when engine is rotated.

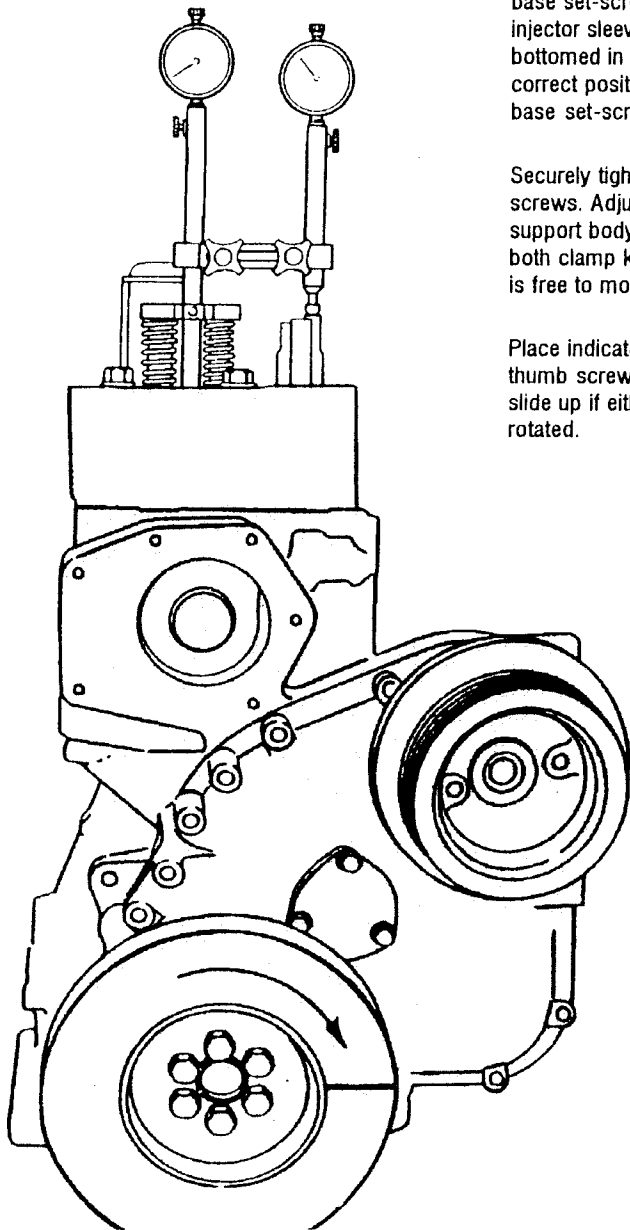

Injector Timing Gage For Cummins Engines (NH, NT, L10 & V Models)

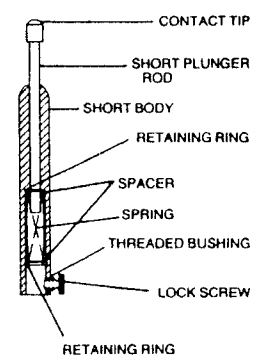
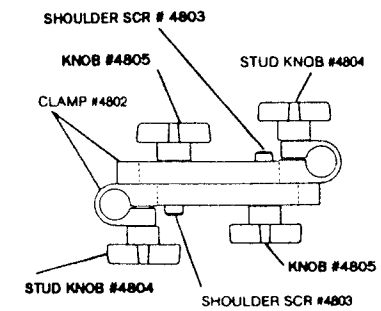
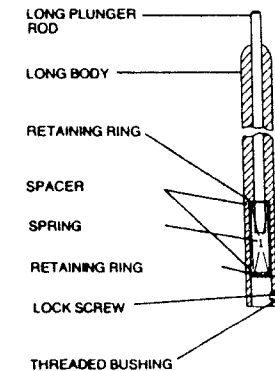
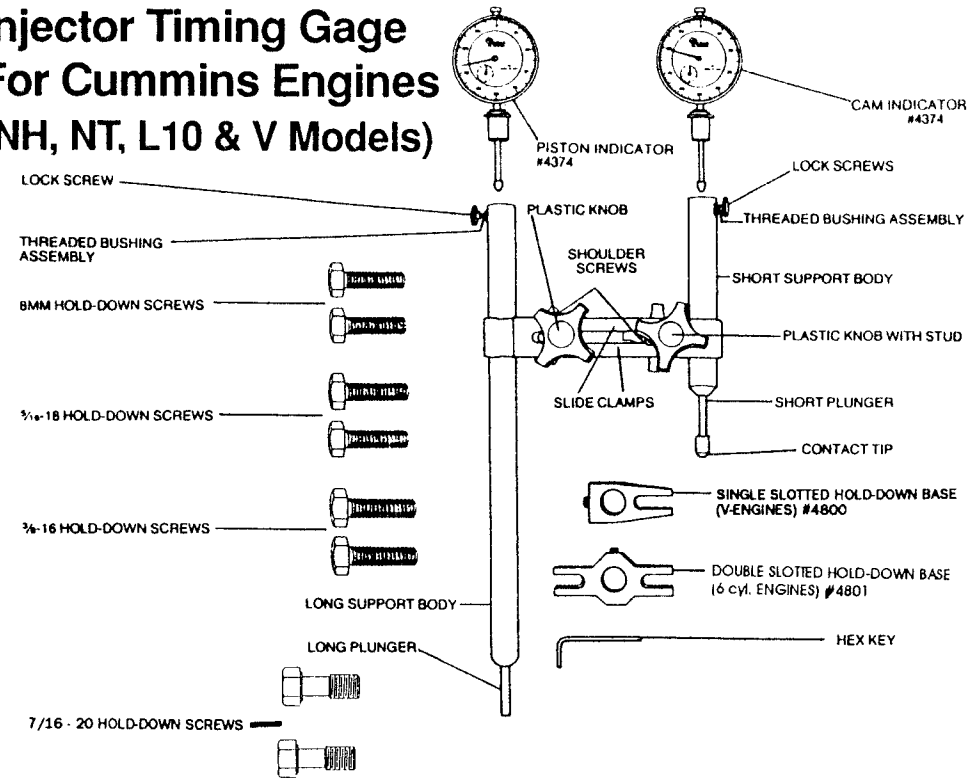

Fitted Case #4806

Continued

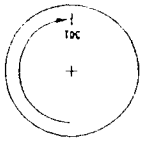

Step 1:

- Turn engine clockwise until piston indicator shows piston to be at top dead center (TDC). Watch that both indicators rotate in the same direction. If not, continue turning engine one revolution. The indicators must rotate in the same direction.
- With the engine at TDC, loosen the piston indicator thumb screw and insert the indicator fully into the support body until the revolution counter has completely rotated. The small rev counter hand should be at zero on the black numbers (zero on the red numbers if provided), and the large hand should be at approximately 12 o'clock. Tighten the piston indicator thumb screw, leaving additional travel so that indicator does not bottom out. Set outer dial of indicator to zero and recheck by rocking engine.
- Place chalk mark on hub for TDC reference.

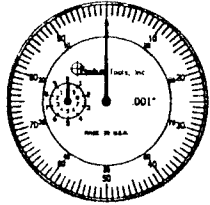

PISTON INDICATOR

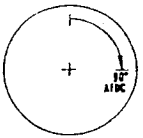

Step 2:

- Turn engine to approximately 90° (60° on V's) after top dead center (ATDC).
- Loosen the injector cam indicator thumb screw and insert the indicator fully into the support body until the rev counter has completely rotated. The small rev counter hand should be at zero on the black numbers (zero on the red numbers if provided), and the large hand should be at approximately 12 o'clock. Tighten thumb screw, leaving additional travel so that indicator does not bottom out. Set outer dial of indicator to zero.

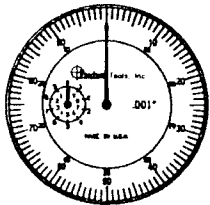

INJECTOR CAM INDICATOR

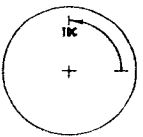

Step 3:

Turn engine counter clockwise back to TDC. Rock engine to double check that piston indicator reads exactly zero at TDC.

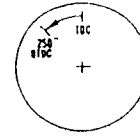
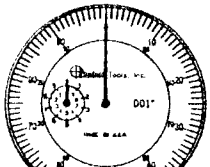

Step 4:

Turn engine counter clockwise back to .250° BTDC. The piston indicator should have the small rev counter hand between the black 7 and 8 (2 and 3 on the red numbers if provided). The large hand should point to the red 50 on the outer dial.

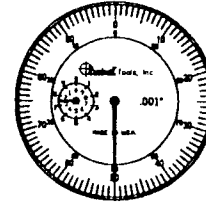

PISTON INDICATOR

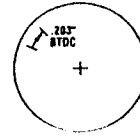

Step 5:

By first turning engine to .250° BTDC (step 4), all backlash will be taken up. Turn engine clockwise to .203° BTDC. The large hand should be 3 graduations left of the zero on the outer dial. The small rev counter hand should be approximately at the black 8 (red 2 if provided).

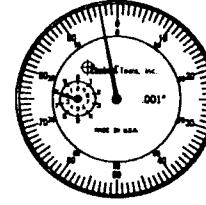

PISTON INDICATOR

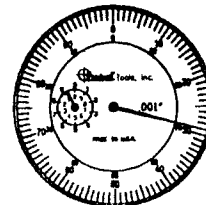

INJECTOR CAM INDICATOR
(EXAMPLE READING ONLY)

Step 6:

- Read injector cam indicator, noting the rev counter if it has traveled more than one revolution.
- Consult Cummins Service Manual to verify that timing is correct. If not, compensate for error as outlined in manual.