

Other Precision Tools from



"Your Automotive Measuring People"

Manufacturer approves  
of the following  
batteries only:

Toshiba CR2032

Renata B/CR2032

Vcar CR2032

Rayovac CR2032

Maxell CR2032

Sanyo CR2032

Panasonic CR2032

Varta CR2032

Eveready CR2032

- Micrometers
  - Inside
  - Outside
  - Disc Brake
  - Depth
  - Sets
- Dial Indicators & Test Sets
- Magnetic Bases
- Machinists Tools
- Dial Calipers
- Electronic Digital Calipers
- Torque Wrenches
- Straight Edges

Write for Catalog

 **Central Tools, Inc.**

456 Wellington Avenue  
Cranston, Rhode Island 02910

06459-64-000 4/97 Copyright Central Tools, Inc.

Printed in U.S.A.



## No. 6459 Digital Rotor Gage

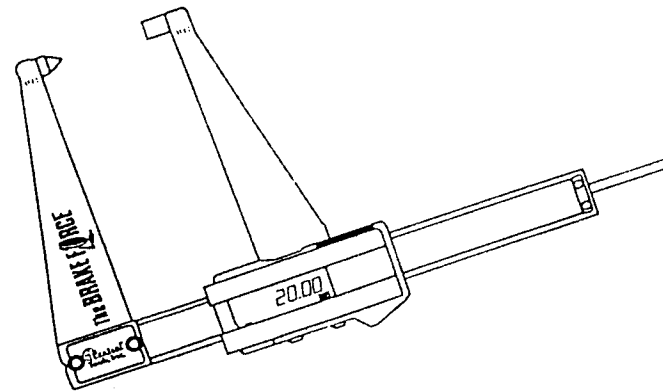

Use on:

- Domestic & Foreign Vehicles
- Light-Heavy Duty
- Inch/Metric

 **Central Tools, Inc.**  
Cranston, Rhode Island 02910

**MEASURING RANGE:** 0-2.250" and 0-58mm+

**MEASURING DEPTH:** 3.250" (82mm)

**ANVILS:** ONE FLAT AND ONE POINTED

**BATTERY:** CR2032

**PROTECTIVE CASE:** CENTRAL #4532

## INSTRUCTIONS FOR USE

1. Before using your gage, it must be calibrated. With the display showing "SET" mode, simply slide the moving arm so that the flat and pointed anvils are in contact, making certain the anvils are clean and free of foreign matter. Depress the zero button. Your gage is now calibrated.
2. Select inch or metric measurement by depressing the mm/in button. This switch may be depressed at any time while in the "SET" mode to convert measurements.
3. Open the arms. Place them over and close them on the rotor to be measured. Your measurement is instantly displayed.
4. Take care that the gage is perpendicular to the rotor to prevent measurement error. To assure this, keep the flat anvil in full contact.
5. Use of the pointed anvil allows measurement of the real minimum thickness of a scored rotor.
6. To measure score depth only, measure the rotor thickness adjacent to the score, press the zero button, open the gage, place the pointed anvil in the score and close the gage. The measurement shown is the actual score depth, with a (-) sign in front.
7. To measure a rotor in a position where the display cannot be viewed, close the arms on the rotor at the point to be measured. Press the zero calibration switch. Open the arms and remove the gage. Close the arms. The reading is the actual rotor thickness, with a (-) sign in front.
8. Use a light but firm gaging pressure to hold the anvils against the piece being measured (against each other when calibrating). Consistent gaging pressure will result in repeatable measurements.

## CARE OF YOUR GAGE

1. Your new Digital Rotor Gage is a highly precise yet extremely simply to use measuring instrument. Care of this gage will assure its utility for years to come.
2. Do not apply any voltage to the gage, such as marking it with an electric marking pen.
3. Do not tamper with the electronics. **Return to the factory for service.**
4. Keep the gage free from solvents, water and oil. **Do not immerse in any liquids.**
5. Prevent the accumulation of contaminants on the measuring bar, by periodically wiping the bar with a clean, dry cloth.
6. Do not apply excessive force or shock to the gage.
7. When not in use, return the gage to its protective case.
8. Do not store in direct sunlight or near a heat source.
9. Avoid quick temperature changes, such as going from an air conditioned office to a hot shop floor. Condensation may result, fogging up display and causing damage to the electronics.
10. For technical assistance, call 1-800-866-5287.

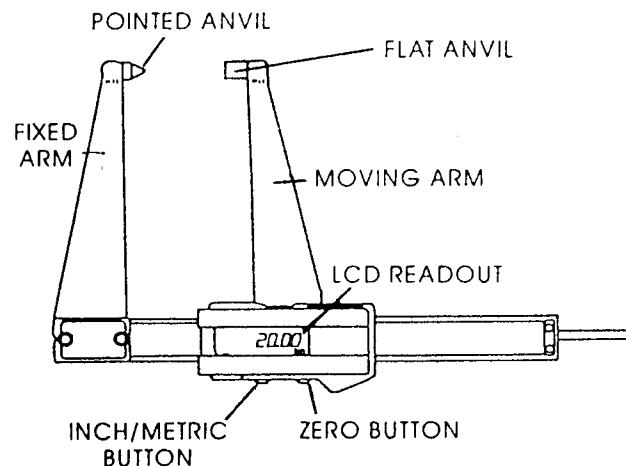

## Instructions for operating your Digital Caliper

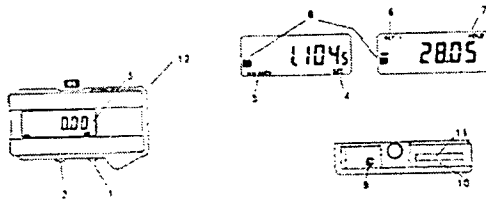

1. Press-button for: ON/OFF, zero setting and memory (HOLD)
2. Press-button for: mm/inch conversion and mode selection
3. Combined display:
  - 4. • Shows function of button 1
  - 5. • Shows function of button 2
  - 6. • Indicates mode selected through 2
  - 7. • Indicates the measurement selected for memory (hold)
  - 8. • Portrays termination of battery life
9. Reset port
10. Cable connection for RS-232 data output
11. "Flip-off" panel for easy battery exchange
12. Complete Cover

### **IMPORTANT! IMPORTANT! IMPORTANT!**

You must reset the electronics whenever replacing the battery. To reset, remove the small round rubber cover just above the digital display. Carefully insert the "zero" setting pin to activate the internal switch. The display will now come on. Replace the rubber cover.

## Detailed Instructions

### Starting the caliper

A brief press of button (1) will switch ON the caliper unit.

Having switched on, the display shows the functions selected prior to switching OFF.

### Measuring-functions:

The caliper has two distinctive functions:

- Function 1: This is an automatic condition after battery replacement whereby the mm/ inch selection can be made and a zero setting made at any point.
- Function 2: Button (1) allows a memory set (hold) or the transmission of a measured value through the RS-232 output.

### Battery replacement

"Flip-off" the small panel (10) and (11) on the reverse side of the cover. Remove battery. When inserting the new battery, ensure that the (+) pole is positioned at the top. An inverted + pole cannot damage the electronic unit, it simply will not function.

Replace the two small panels and reset the module.  
(Activate the button through reset port (9) with pointed object).

This display will show as described in function 1 with the following result:

#### Measuring - using function 1:

##### — Zero setting:

Press button (1) until the (REF 1) display point (6) appears. Release the button and zero will be displayed.

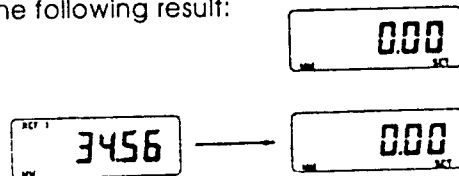

##### — Changing the measuring format (mm/inch):

Press button (2) until the display (e.g. mm) is cleared. Release the button and the new format (e.g. inch) will be displayed.

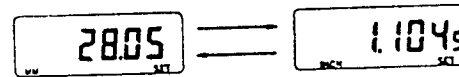

##### — Changing the mode:

A prolonged press of button (2) is needed to obtain change of function as indicated by (5,6).

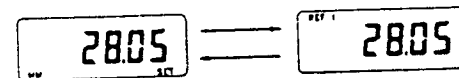

#### Measuring - using function 2:

##### — Memorizing a (HOLD) value:

A prolonged press of button (1) is needed to obtain the function "HOLD" on the display. The measured value is now retained until the "HOLD" is cleared. (Renewed pressing of button (1).)

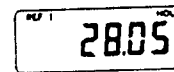

*Note:* If the caliper is connected to a computer or printer using RS-232 output and the measured value is transmitted, the HOLD function will be cleared. It is not possible to return to function 1 while "HOLD" is displayed.

##### — Application of button (2):

Only a prolonged press of this button is needed to reset to function 1.

Switching "OFF" the caliper display unit:

A prolonged press of button (1) will switch "OFF" the display. The actual "set" function has no influence.

The original value is retained providing the slide is not displaced.