

Other Precision Tools from



"Your Automotive Measuring People"

Manufacturer approves
of the following
batteries only:

Toshiba CR2032

Renata B/CR2032

Vcar CR2032

Rayovac CR2032

Maxell CR2032

Sanyo CR2032

Panasonic CR2032

Varta CR2032

Eveready CR2032

- Micrometers
- Brake Force
 - Rotor Gage
 - Drum Gage
 - Rotor/Ball Jt. Gage
 - Wheels On Rotor Gage
 - Wheels On Drum Gage
- Dial Indicator Sets
- Magnetic Bases
- Machinists Tools
- Dial Callipers
- Digital Callipers
- Torque Wrenches
- Straight Edges

Write for Catalog

 **Central Tools, Inc.**

456 Wellington Avenue
Cranston, Rhode Island 02910

06496-64-000 4/98

Copyright Central Tools, Inc.

Printed in U.S.A.



The **BRAKE FORCE**

**Wheels On Rotor Gage
No. 6496**

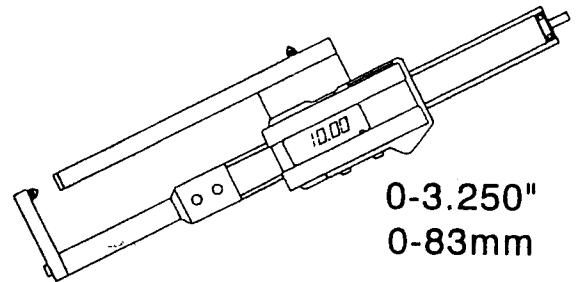

0-3.250"
0-83mm

- Measures Rotor Thickness with
Wheels Mounted.
- Medium and Heavy Duty Vehicles
- Inch/Metric

 **Central Tools, Inc.**

Cranston, Rhode Island 02910

MEASURING RANGE: 0-3.250"+ and 0-83mm+

MEASURING DEPTH: 1" (25mm)

ANVILS: ONE POINTED AND EITHER ONE FLAT
OR ONE POINTED

BATTERY: CR2032 (CENTRAL #4103)

PROTECTIVE CASE: CENTRAL #4532

INSTRUCTIONS FOR USE

1. Before using your gage, it must be calibrated. With the display showing "SET" mode, simply slide the moving arm so that the flat and pointed anvils are in contact, making certain the anvils are clean and free of foreign matter. Depress the zero button. Your gage is now calibrated.
2. Select Inch or metric measurement by depressing the mm/in button. This switch may be depressed at any time while in the "SET" mode to convert measurements.
3. Open the arms. Place them over and close them on the rotor to be measured. Your measurement is instantly displayed.
4. Take care that the gage is perpendicular to the rotor to prevent measurement error. To assure this, keep the flat anvil in full contact.
5. Use of the pointed anvil allows measurement of the real minimum thickness of a scored rotor.
6. To measure score depth only, measure the rotor thickness adjacent to the score, press the zero button, open the gage, place the pointed anvil in the score and close the gage. The measurement shown is the actual score depth with a (-) sign in front.
7. To measure a rotor in a position where the display cannot be viewed, close the arms on the rotor at the point to be measured. Press the zero button. Open the arms and remove the gage. Close the arms. The reading is the actual rotor thickness, with a (-) sign in front.
8. Use a light but firm gaging pressure to hold the anvils against the piece being measured (against each other when calibrating). Consistent gaging pressure will result in repeatable measurements.
9. Lining thickness can be measured from the friction surface down to the rivets, if present, or down to the steel in the case of the bonded design. In either case, first thoroughly clean the brake pad or shoe with brake cleaner. Any foreign material present can cause errors.
 - Riveted: Hold the end of the gage upright and square against the friction surface over the rivet hole. Extend the depth rod by sliding the moving arm. Obtain the measurement when the depth rod contacts the top of the rivet head.
 - Bonded: Hold the end of the gage upright and square against the friction surface near the edge of the pad or shoe. Extend the depth rod by sliding the moving arm, so the rod extends down past the edge of the friction material. Obtain the measurement when the depth rod contacts the steel portion of the pad or shoe.

CARE OF YOUR GAGE

1. Your new BRAKE FORCE Wheels On Rotor Gage is a highly precise yet extremely simple to use measuring instrument. Care of this gage will assure its utility for years to come.
2. Do not apply any voltage to the gage, such as marking it with an electric marking pen.
3. Do not tamper with the electronics. **Return to the factory for service.**
4. Keep the gage free from solvents, water and oil. **Do not immerse in any liquids.**
5. Prevent the accumulation of contaminants on the measuring bar by periodically wiping the bar with a clean, dry cloth.
6. Do not apply excessive force or shock to the gage.
7. When not in use, return the gage to its protective case.
8. Do not store in direct sunlight or near a heat source.
9. Avoid quick temperature changes, such as going from an air conditioned office to a hot shop floor. Condensation may result, fogging up display and causing damage to the electronics.
10. For technical assistance, call 1-800-866-5287.

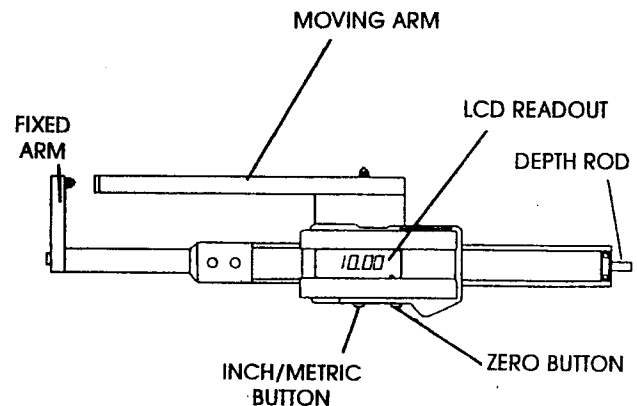

Modes

The unit has two functional modes. The first is the normal measuring mode, and the second allows a reading to be held on the display. To change between modes, press and hold button #2.

The word "SET" in the lower right corner of the display indicates the normal measuring mode is selected.

The word "REF 1" in the upper left corner of the display indicates the memory mode is selected.

Normal Measuring Mode - Inches and Millimeters

The word "SET" should appear in the lower right corner of the display which indicates the normal measuring mode is selected. Prior to taking a measurement, the calibration of the caliper should be checked as follows: completely close the jaws, and briefly press button #1 to reset the display to zero.

To switch the measurement units between inches and millimeters, briefly press button #2. The display changes between inches and millimeters each time the button is depressed. This button may be pressed at any time. Once a measurement has been taken, pressing button #2 will convert between millimeters and inches.

Memory Mode

The memory mode may be used to hold a particular measurement on the display. (Note that the tool cannot be recalibrated to zero while in the memory mode, so, it is usually best to begin in the "Normal Measuring Mode" - see above.) Enter the memory mode after the tool has been reset to zero, as explained above. The memory mode is useful, for example, when a measurement must be taken in a position where it is difficult to read the display directly. In a case such as this, the measurement can be "frozen" on the display and read after the tool has been removed from the difficult position.

To enter memory mode, press and hold button #2 until the word "REF 1" appears in the upper left corner of the display. It is now possible to perform a measurement, and a brief press of button #1 will cause the measurement to be held on the display. "HOLD" will be displayed in the upper right corner of the display.

If the jaws are moved while a value is being held on the display, the display will not change; however, once the memory is cleared with another brief press of button #1, the display will update with the correct new value based on the new position of the jaws.

Battery Replacement - Important!

When the low battery indicator (#8) appears on the display, the battery should be replaced. Carefully pry off the two slender rectangular rubber plugs (#10 and #11) on the upper surface of the display cover. The old battery may be removed by *carefully* prying it out with the accessory tool provided, a jeweler's screwdriver, or the like. When inserting the new battery, be sure the positive (+) pole is facing outward. (If the battery is accidentally inserted backward, it will not cause damage; however the unit will not function). The unit will automatically reset itself - the word "rESEt" will flash very briefly on the display. Replace the two rubber plugs.

Troubleshooting

If the tool does not seem to be operating correctly - digits not responding to jaw movement, "Err", "Mode", or other unfamiliar messages on the display, it can be reset as follows: Simultaneously press and hold both buttons. After a few seconds the display will go completely blank. At this point, release both buttons. The word "rESEt" will flash very briefly on the display, and normal operation will be restored.

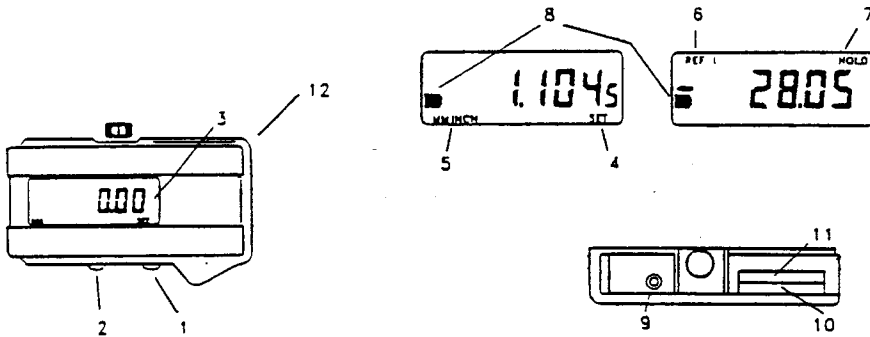

1. Pushbutton for ON/OFF, zero set, and memory ("HOLD")
2. Pushbutton for mm/inch conversion and mode selection
3. Display
4. "SET" indicator
5. Measurement units indicator
6. "REF 1" indicator
7. "HOLD" (memory) indicator
8. Low battery indicator
9. Reset port
10. Port for optional RS232 computer interface cable (not available from Central Tools, Inc.)
11. Battery compartment
12. Cover assembly

Turning the Display On/Off

A brief press of button #1 will switch ON the display. A prolonged press of button #1 will switch OFF the display.