

PRECISION TOOLS FROM  **Central Tools, Inc.**
"Your Automotive Measuring People"

Micrometers

Rod & Tubular Types

Inside

Outside

Depth

Sets

Dial Indicators & Test Sets

Magnetic Bases

Machinists Tools

Dial Calipers

Electronic Digital Calipers

Torque Wrenches

Write for Catalog

 **Central Tools, Inc.**
456 Wellington Avenue
Cranston, Rhode Island 02910

06491-64-000 7/97 Copyright© Central Tools, Inc. Printed in U.S.A.

 **Central Tools, Inc.**
No. 6491

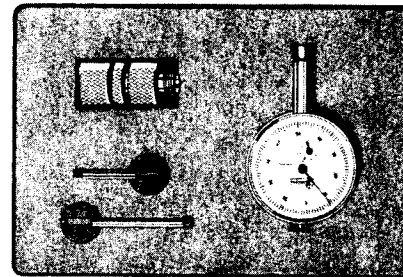

**MOTORCYCLE TIMING GAGE
FOR 14mm Plug Size**

 **Central Tools, Inc.**
Cranston, Rhode Island 02910

INSTRUCTIONS FOR USING #6491

1. Remove spark plug and ground spark plug wire. Be certain the threads in head are completely clean and free of burrs.
2. Insert indicator into adaptor and tighten adaptor cap to obtain snug fit. Tighten lock ring against cap.
3. Select contact and screw into indicator plunger, finger tight.
4. Carefully screw assembly into spark plug hole.
5. Locate top-dead-center (TDC). This is where the indicator hand stops and reverses direction as the engine is cranked over. Set indicator to zero at TDC.
6. It may be necessary to slide the indicator up or down in the adaptor so that the indicator is positioned to show TDC.
7. Rotate engine until piston is in correct position before TDC for spark to occur. Consult manufacturers specifications.
8. Adjust points to open with piston in this position.
9. Rotate engine and recheck setting.

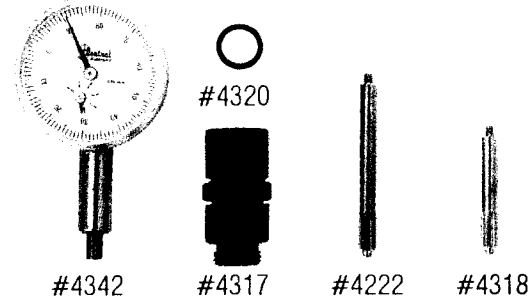

- #4342 Indicator
- #4317 Adaptor
- #4318 Contact, 1-1/2"
- #4222 Contact, 2"
- #4320 "O" Ring

Do not over-tighten contact points. Do not use in a manner which will cause side thrust on contact, such as using in an angled spark plug hole. * Damage from this is not covered by warranty.

#4214



1" contact extension not included in set. Threaded Male and Female, for use with contacts in set for greater reach.

*6480 or 6481 may be used